

175 Eloy Road, North Bay, Ontario, Canada P1B9T9  
 PH 1.705.476.4500 FX 1.705.476.8811  
 mtsales@millertechnology.com  
 © 2016 Miller Technology Inc. All Rights Reserved  
 www.millertechnology.com



# MAX



**Built for Hard Rock Miners**

## MILLER MAX

### CONCEIVED THROUGH EXPERIENCE

Four decades of designing, manufacturing and servicing the underground mining industry has taught Miller Technology a few things. So we set out to create the new standard for Mid-range Utility Vehicles (MUV)

### INTRODUCING THE MILLER MAX:

- Purpose-built increasing up and down ramp performance
- Dependable availability, shift after shift
- Reduced maintenance costs
- Unlimited configurations available

Miller MAX: The Next Generation

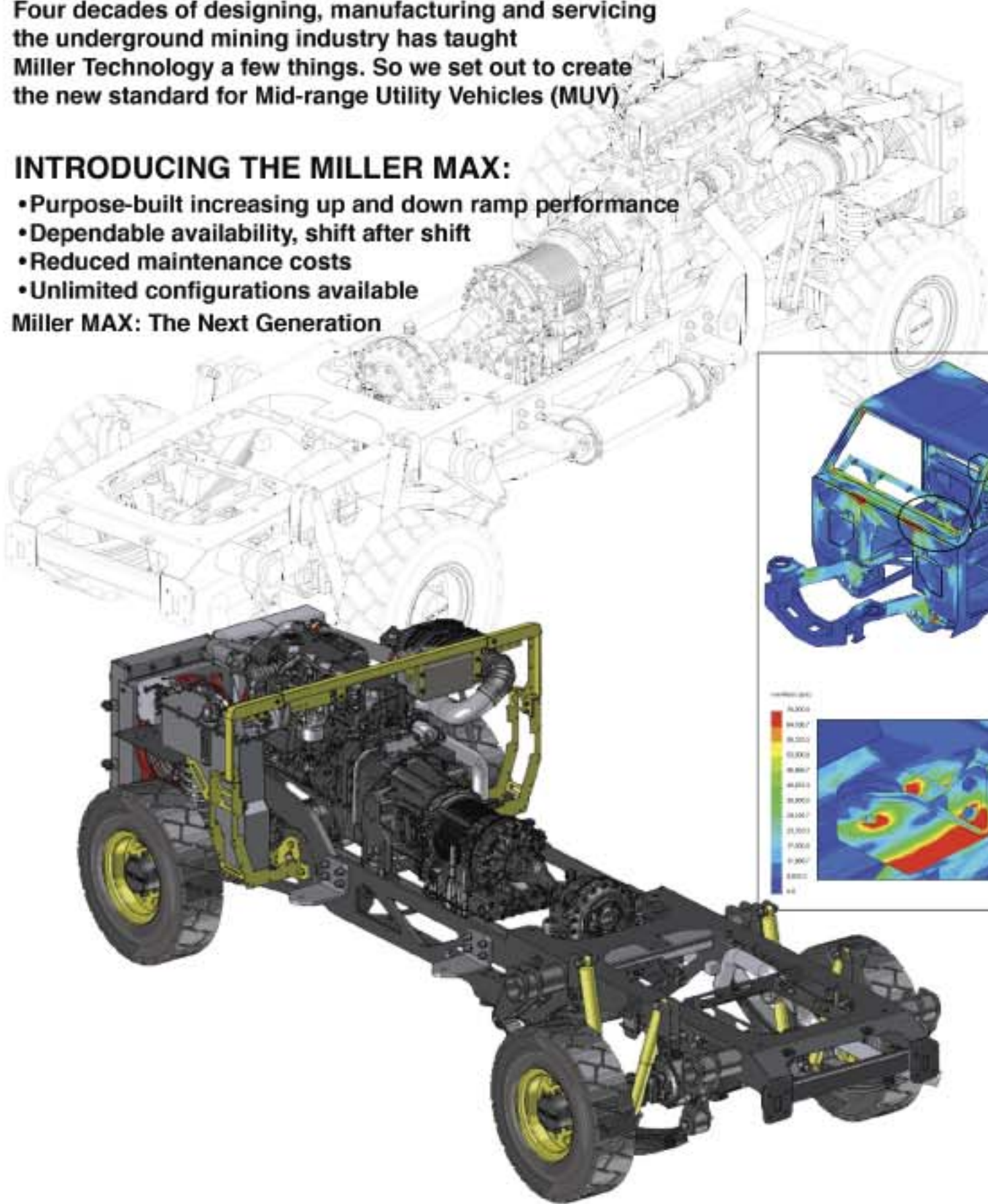

## ENGINEERED TO THE MAX

The next generation MUV applies everything our engineering team has learned:

- 5- ton payload
- Integrated ROPS/FOPS Structure for safety
- Same size-envelope and turning radius as industry standard Toyota Land Cruiser based vehicles
- Internal wet-disc service brakes with integrated SAHR Park / Emergency brakes provide reliable, safe braking
- Heavy duty Allison transmission fitted with built in down-ramp retardation for maximum durability and extended service brake life
- Industrial Cummins diesel engine for power and longevity

Miller MAX: Built in Canada for Hard Rock Miners

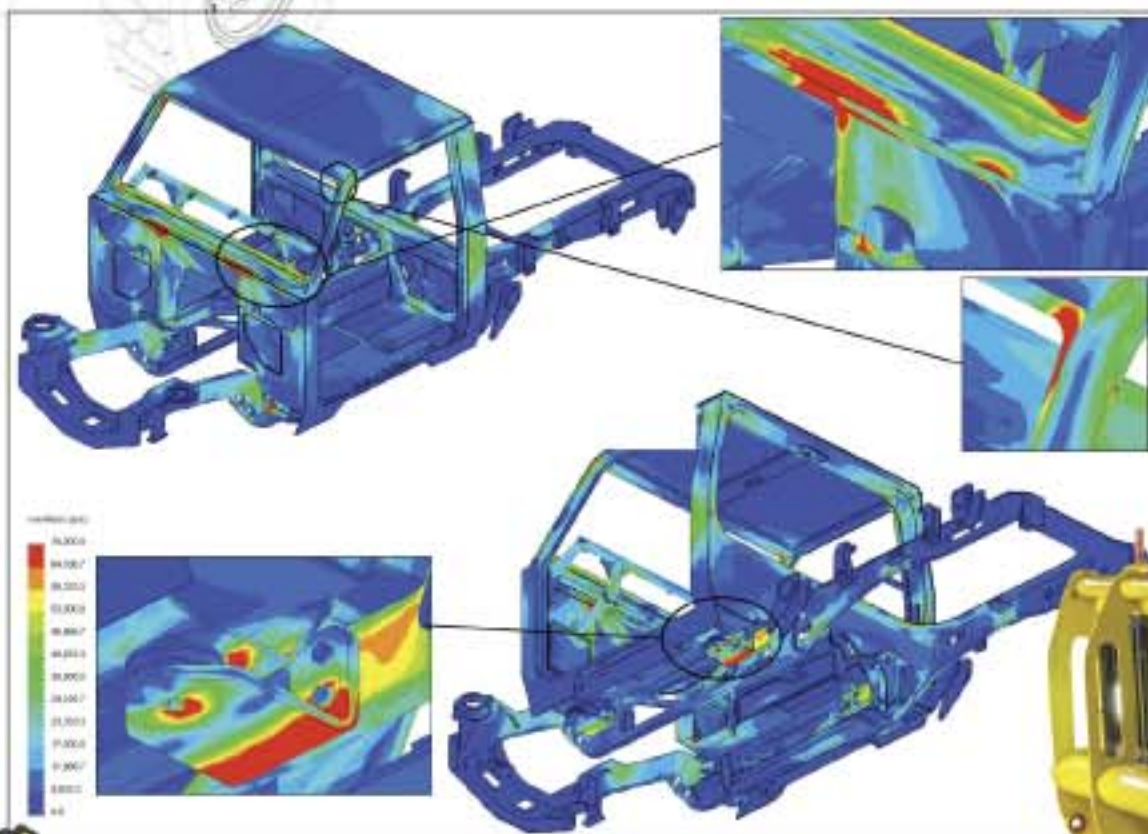

## INNOVATIVE MODULAR DESIGN

•UNLIMITED CONFIGURATIONS

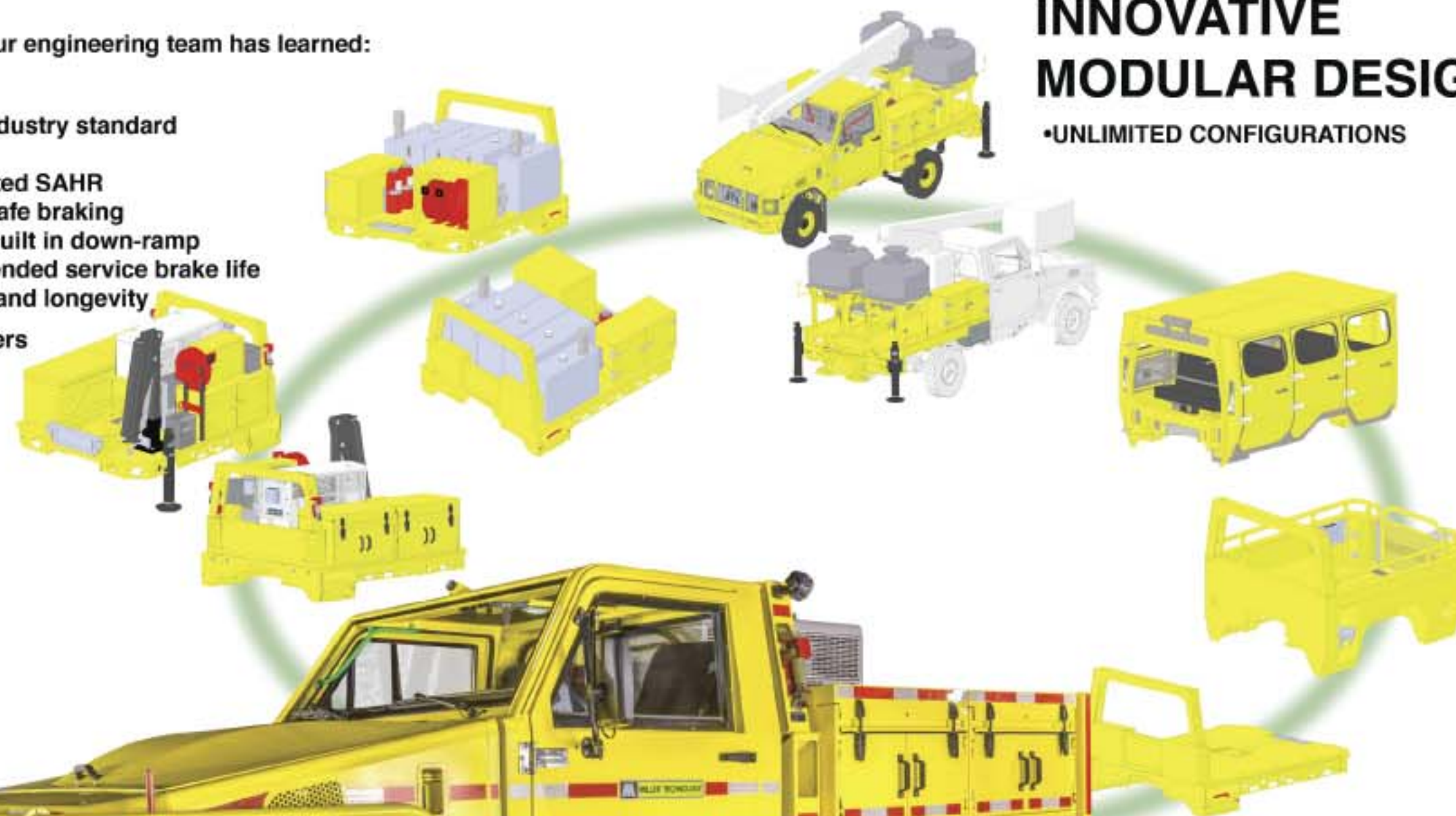

## THOROUGHLY EVALUATED AND TESTED

- Computerized Finite Element Analysis (FEA)
- Grueling Hard Rock Underground testing
- 2-year bumper to bumper warranty
- 5-year frame warranty

